

SERIES TCC

TRIHEDRAL CORNER REFLECTORS



FEATURES:

- High Radar Cross Section (RCS)
- High return over wide look angle
- Available in many sizes up to 8.5"
- Secure mounting bracket
- Rugged Construction
- 1/4"-20 mounts to standard tripod

APPLICATIONS:

- Radar characterization
- High RCS reference
- Range finding

DESCRIPTION

Millitech trihedral corner reflectors provide a very high Radar Cross Section (RCS) target for radar testing and characterization. With suitable alignment the effect of clutter on measurements such as that caused by vehicles, terrain and structures can be greatly reduced. Select from the variety of sizes available to attain the desired RCS for the frequency of your application.

These reflectors are highly tolerant to misalignment by virtue of their construction and are commonly used to increase the RCS of objects needing emphasis in the field or on an antenna range. Due to their geometry these passive devices offer the highest possible RCS of any object per unit volume.

This precision machined component is an essential part to any radar system needing characterization in the field or any application where emphasis on an object is required.

These devices are easily mounted to a tripod with standard 1/4"-20 hardware or can be affixed to permanent vehicles or structures to provide an increased likelihood of a strong radar hit.

OUTLINE DRAWINGS*

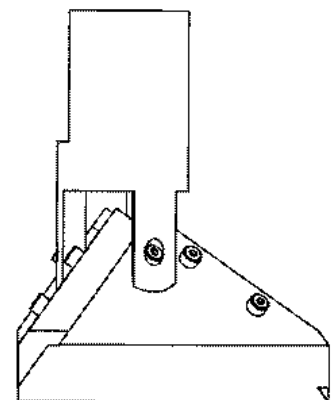
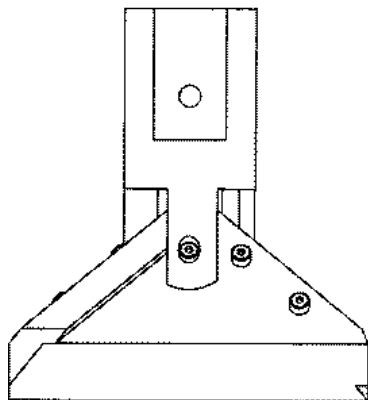
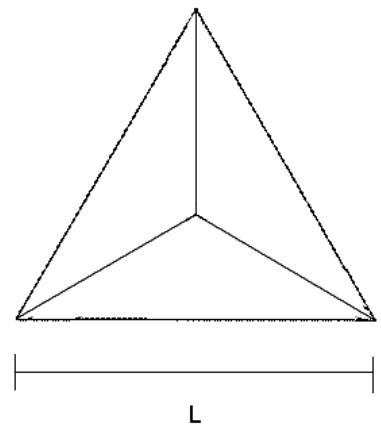
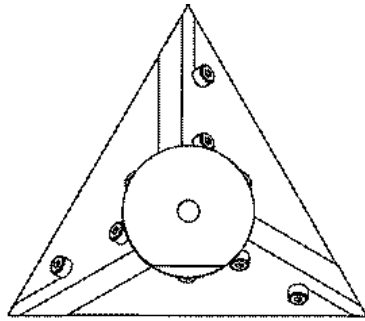

*The outlines shown may not reflect the latest information. Please contact Millitech for current outline drawings.

ELECTRICAL CHARACTERISTICS

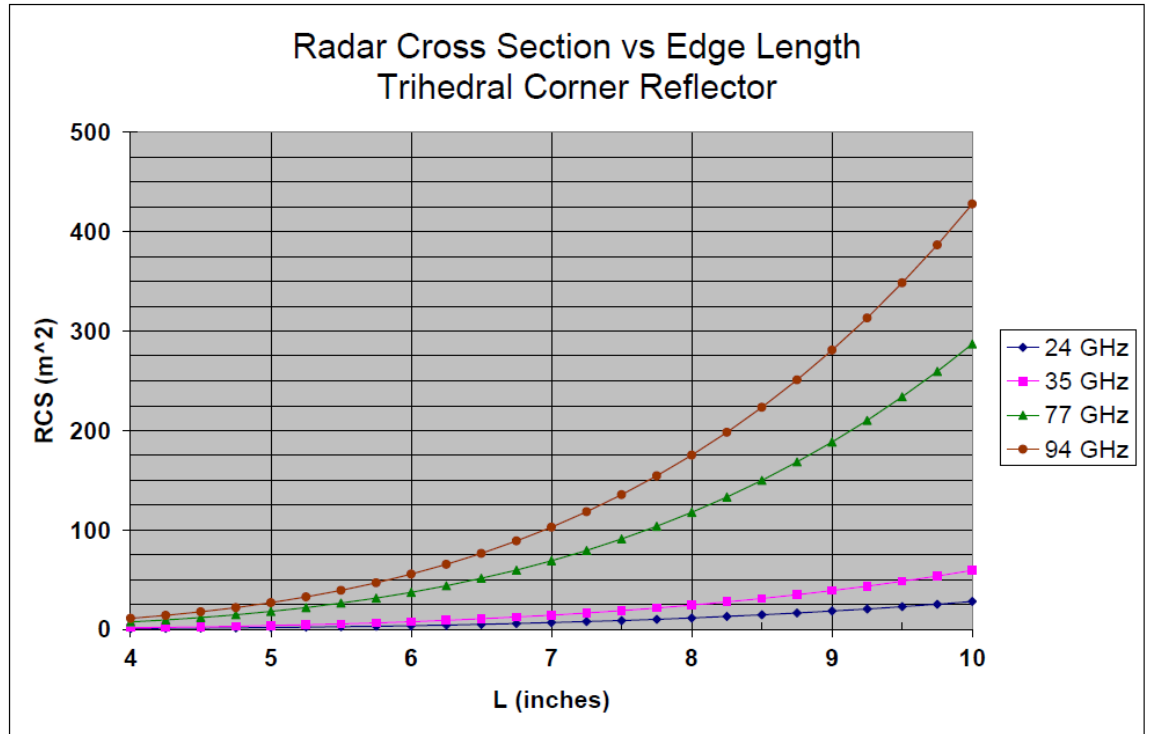

L vs. RCS is computed by the exact solution for the Trihedral Corner: $RCS = (\pi L^4) / (3\lambda^2)$
 RCS in dBsm is computed by taking: $10\log(RCS[\text{meters}^2])$

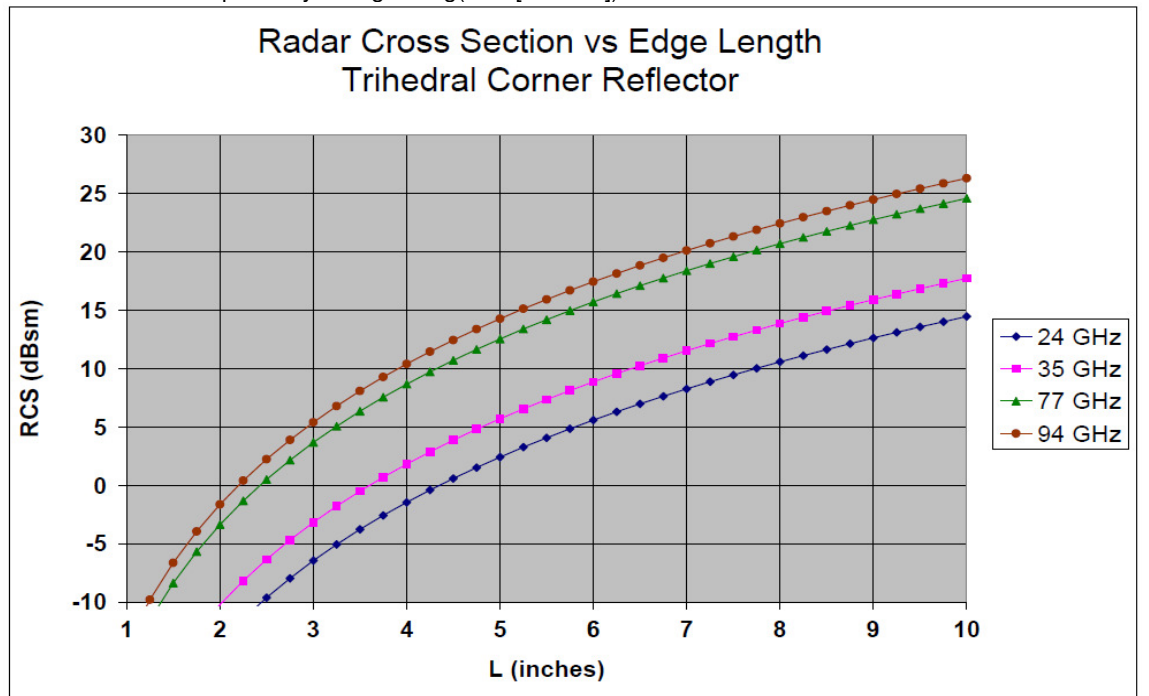



HOW TO ORDER

Specify Model Number
TCC-00-AAAA0

AA = Edge Length, L. Given as:

Inches x 1000

Example:

For L=7", the Model number is TCC-00-07000